



## Opti Max2100 1 GHz Segmentable Cabinet Node Technical Specifications

### General Specifications

| Characteristic                              |   | 85/105 Split  |            | 65/85 MHz Split                    |            | 42/54 MHz Split                    |   |                          |    |                          |  |
|---|---|---|------------|------------------------------------|------------|------------------------------------|---|--------------------------|----|--------------------------|--|
| Downstream<br>Optical                       | Optical Input Level Range                       | -6 to 3 dBm without optical AGC; -6 to 0 dBm or -3 to +3 dBm with optical AGC |            |                                    |            |                                    |   |                          |    |                          |  |
|   | Optical Input Wavelength, nm                    | 1290 to 1600  |            |                                    |            |                                    |   |                          |    |                          |  |
|   | Equivalent Input Noise, pA/Hz <sup>0.5</sup>    | 5   |            |                                    |            |                                    |   |                          |    |                          |  |
|   | Optical Input Testpoint Level, V/mW             | 1 ± 10%   |            |                                    |            |                                    |   |                          |    |                          |  |
| Downstream RF                               | Operating Passband                              | 105 to 1002 MHz   |            | 85 to 1002 MHz                     |            | 54 to 1002 MHz                     |   |                          |    |                          |  |
|   | Output Level @ 1002 MHz dBmV, min. <sup>1</sup> | See Note 1  |            | See Note 1                         |            | See Note 1                         |   |                          |    |                          |  |
|   | Factory Aligned Tilt <sup>2</sup> , dB          | 5 ± 1.0   |            | 5 ± 1.0                            |            | 5 ± 1.0                            |   |                          |    |                          |  |
|   | Flatness <sup>3</sup> , typ./max.               | ±0.6/±1.2 dB (from 110 to 1002 MHz)   |            | ±0.6/±1.2 dB (from 90 to 1002 MHz) |            | ±0.6/±1.2 dB (from 60 to 1002 MHz) |   |                          |    |                          |  |
|   | Return Loss, @ 40 MHz, dB, min.                 | 18.0-1.5 dB/octave  |            | 18.0-1.5 dB/octave                 |            | 18.0-1.5 dB/octave                 |   |                          |    |                          |  |
|   | Port to Port isolation, dB, typ.                | >60   |            | >60                                |            | >40                                |   |                          |    |                          |  |
|   | Thermal Level Stability <sup>4</sup> , dB, max. | ±1.5  |            | ±1.5                               |            | ±1.5                               |   |                          |    |                          |  |
|   | Optical AGC Accuracy, dB, max <sup>5</sup>      | ±0.75   |            | ±0.75                              |            | ±0.75                              |   |                          |    |                          |  |
| RF Output Testpoint, dB                     | -20 ± 0.75                                      |   | -20 ± 0.75 |                                    | -20 ± 0.75 |                                    |   |                          |    |                          |  |
| Performance                                 | Channel Performance <sup>6</sup>                | 60 PAL <sup>7,8</sup>   |            | 42 CENELEC <sup>9</sup>            |            | 60 PAL <sup>10,11</sup>            |   | 42 CENELEC <sup>12</sup> |    | 79 NTSC <sup>13,14</sup> |  |
|   | Frequency, MHz                                  | 1002/870/47   |            | 870/47                             |            | 1002/870/47                        |   | 870/47                   |    | 1002/870/550/54          |  |
|   | Output Level, dBμV                              | 114/112/100   |            | 112.5/104.5                        |            | 114/112/100                        |   | 112.5/104.5              |    | —                        |  |
|   | Output Level, dBmV                              | —   |            | —                                  |            | —                                  |   | —                        |    | 54/52/47/39              |  |
|   | Carrier to Noise Ratio, 5 MHz, dB/dBm input     | 57/ >-5.5   |            | 57.5/ >-6.0                        |            | 57/ >-5.5 dBm                      |   | 57.5/ >-6.0              |    | —                        |  |
|   | Carrier to Noise Ratio, 4 MHz, dB/dBm input     | —   |            | —                                  |            | —                                  |   | —                        |    | 58/ >-5.5                |  |
|   | Composite Triple Beat, -dBc                     | 73  |            | 68                                 |            | 73                                 |   | 68                       |    | 71 dBc                   |  |
|   | Composite 2IM, -dBc                             | 69  |            | 65                                 |            | 69                                 |   | 65                       |    | 66                       |  |
|   | Cross Modulation, per NCTA std, -dB             | 68  |            | 68                                 |            | 68                                 |   | 68                       |    | 68                       |  |
| Composite Intermod. Noise, dB <sup>15</sup> | 59  |   | —          |                                    | 59         |                                    | — |                          | 61 |                          |  |

Continue to next page

# Technical Specifications

**General Specifications**

| Characteristic                    | 85/105 Split                                       | 65/85MHz Split  | 42/54MHz Split  |   |
|-----------------------------------|--|---|---|---|
| <b>Upstream RF</b>                | Operating Passband                                 | 5 to 85MHz  | 5 to 65MHz  | 5 to 42MHz  |
|                                   | Isolated DFB Lasers                                | 1310 ± 20nm (0±1 or 3±1 dBm);<br>1550 ± 25 nm (3±1 dBm)       | 1310 ± 20nm (0 and +3dBm);<br>1550 ± 25nm (+3dBm)             | 1310 ± 20nm (0 and +3dBm);<br>1550 ± 20nm (+3 dBm)            |
|                                   | Isolated CWDM DFB Lasers                           | 1471 to 1611 nm<br>(8 CWDM channels, 20nm spacing)            | 1471 to 1611 nm<br>(8 CWDM channels, 20nm spacing)            | 1471 to 1611 nm<br>(8 CWDM channels, 20nm spacing)            |
|                                   | RF Input Level                                     | 70dBµV (10dBmV) to port;<br>66dBµV (6dBmV) to TX, per carrier | 70dBµV (10dBmV) to port; 66dBµV<br>(6dBmV) to TX, per carrier | 70dBµV (10dBmV) to port; 66dBµV<br>(6dBmV) to TX, per carrier |
|                                   | RF Input Testpoint, dB                             | -20dB ± 0.75  | -20dB ± 0.75  | -20dB ± 0.75  |
|                                   | Optical Power Testpoint, V/mW                      | 1 ± 10%   | 1 ± 10%   | 1 ± 10%   |
|                                   | NPR Dynamic Range, NPR/dB                          | 35/15   | 35/15   | 35/17   |
|                                   | BER Dynamic Range, (QPSK/QAM-16), dB <sup>16</sup> | 43/33   | 43/33   | 45/35   |
| <b>Powering</b>                   | AC Input Voltage                                   | 28 to 65VAC rms (remote), 110-230VAC (local)                  |   |   |
|                                   | AC Current Passing, all ports                      | 10A   |   |   |
|                                   | Power Consumption                                  | 99W max. for fully configured node                            |   |   |
| <b>Physical and Environmental</b> | Connectors   |   |   |   |
|                                   | Optical Fiber Patch Cord Entry Option              | PG16, 5/8-inch UNEF   |   |   |
|                                   | Optical Connector Option                           | SC/APC, FC/APC  |   |   |
|                                   | RF Output Port Options                             | 5/8-inch UNEF, IEC, 3.5/12, F-type (female), PG11             |   |   |
|                                   | RF Testpoints                                      | mini SMB (P/N 1504945)  |   |   |
| Operating Temperature Range       | -20 to 60°C  |   |   |   |

Specification Doc Number 1506247 Rev B, 1503609 Rev B, 1504874 Rev B

- Minimum output level with EQ installed and an optical input of -6dBm: 3.5% OMI = 111 dBµV; 4.0% OMI = 112dBµV; 4.5% OMI = 113 dBµV; 5.0% OMI = 114dBµV. Nodes configured with optical AGC will maintain these output levels over the optical input range.
- Linear tilt with 5dB onboard EQ energized and no plug-in EQ. Tilt is measured from 48 to 1002MHz and is determined using a best fit/least squares formula.
- Measured with respect to tilt from 110 to 1002MHz (85/105 split), 90 to 1002MHz (65/85 split), or 60 to 1002MHz (42/54 split).
- Reference to 23°C with a fixed optical input.
- Output level variation with respect to output level at -3dBm input.
- The distortion values listed are for the node only. To obtain a particular link performance, combine the listed node performance values along with the applicable transmitter performance values.
- Analog channels occupying the 105 to 600MHz (85/105 split), 85 to 600MHz (65/85 split), or 54 to 550MHz (42/54 split) frequency range with digitally compressed channels or equivalent broadband noise to 1002MHz at levels 6dB below equivalent video channels.
- Node configured with a GEQL-1GHZ-100 and the onboard 5dB EQ energized. Optical input of -5.5dBm, 4.5% OMI (85/105 and 65/85 split) or 0dBm, 3.9% OMI (42/54 split). Nodes configured with optional optical AGC will require an OMI of 5% to operate at the listed output levels.
- According to EN50083-3, CENELEC 42-channel loading, with 8dB of tilt from 47 to 870MHz. Optical input of -6dBm, 5% OMI. Specification expressed as a distortion value at the reference output level.
- Analog channels occupying the 85 to 600MHz frequency range with digitally compressed channels or equivalent broadband noise to 1002MHz at levels 6dB below equivalent video channels.
- Node configured with a GEQL-1GHZ-100 and the onboard 5dB EQ energized. Optical input of -5.5dBm, 4.5% OMI. Nodes configured with optional optical AGC will require an OMI of 5% to operate at the listed output levels.
- According to EN50083-3, CENELEC42-channel loading, with 8dB of tilt from 47 to 870MHz. Optical input of -6dBm, 5% OMI. Specification expressed as a distortion value at the reference output level.
- Analog channels occupying the 54 to 550MHz frequency range with digitally compressed channels or equivalent broadband noise to 1002MHz at levels 6dB below equivalent video channels.
- Node configured with a GEQL-1GHZ-110, TLC receiver module and the onboard 5dB EQ energized. Optical input of 0dBm, 3.9% OMI. Nodes configured with optional optical AGC will require an OMI of 5% to operate at the listed output levels.
- Systems operating with digitally compressed channels or equivalent broadband noise from 600 to 1002MHz (65/85 or 85/105 split) or 550 to 1002MHz (42/54 split) will experience a composite distortion (CIN) appearing as noise in the 85 to 600MHz frequency spectrum.
- BER dynamic range is specified for BER 10<sup>-6</sup> without error correction.

## Opti Max2100 1GHz Segmentable Cabinet Node Technical Specification

Refer to the Opti Max2100 Technical Overview Document or the Opti Max2100 Equipment Manual (P/N 1503247) for complete specifications. Specifications are subject to change without notice.

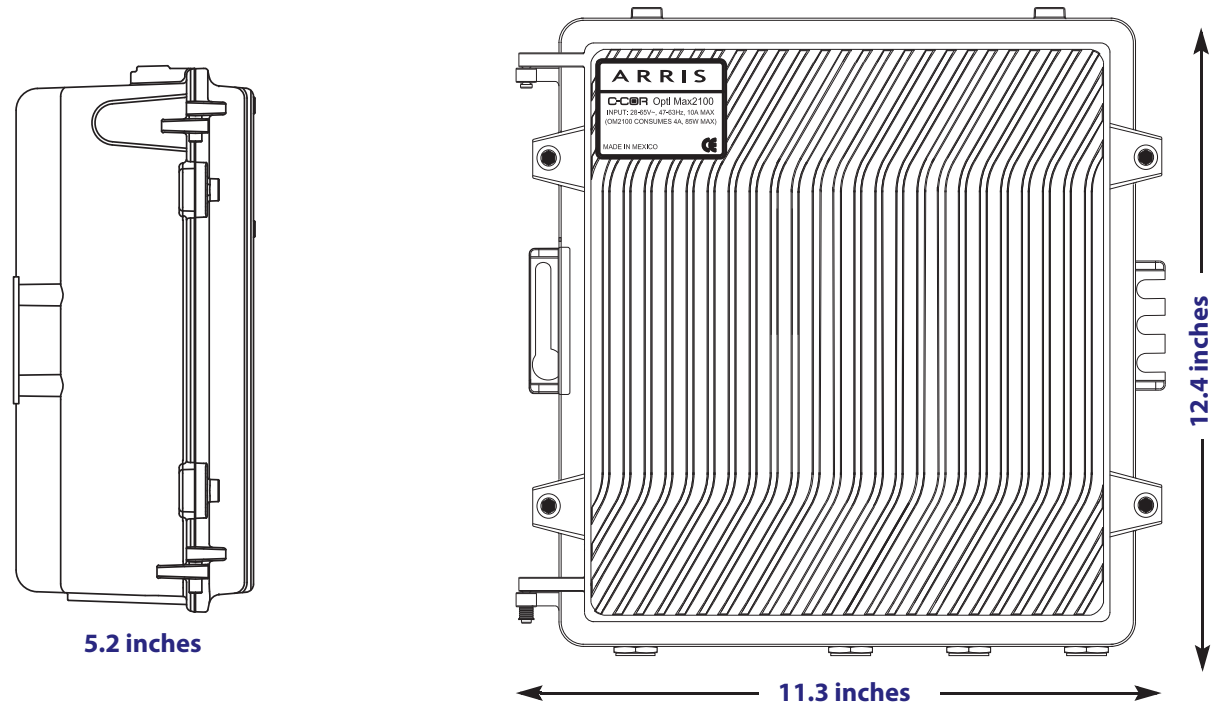

### Opti Max2100 Dimensions

| Characteristic         | Specification                                    |
|------------------------|--|
| Uncrated (H x W x D)   | 12.4 x 11.3 x 5.2 inches (31.4 x 30.3 x 13.2 cm) |
| Crated (H x W x D)     | 16.0 x 13.5 x 7.0 inches (40.6 x 34.3 x 17.8 cm) |
| Crated weight, approx. | 16.06 lbs. (7.28 kg)                             |

### Ordering Information

To configure a product that meets your specific needs, or for any questions, please contact your ARRIS Sales Professional. You may also use our Product Wizard, located at [support.arrisi.com](http://support.arrisi.com) (User ID and password required). If you do not have a user ID and password or have forgotten your password, please use the Sign In Help section indicated.

---

[www.arrisi.com](http://www.arrisi.com)

The capabilities, system requirements and/or compatibility with third-party products described herein are subject to change without notice. ARRIS, the ARRIS logo, Auspice®, C3™, C4®, C4c™, Cadant®, C-COR®, CHP Max™, CHP Max5000™, ConvergeMedia™, Cornerstone®, CORWave™, CXM™, D5®, Digicon®, ENCORE®, Flex Max®, HEMi®, Keystone™, MONARCH®, MOXI®, n5®, nABLE®, nVision®, OpsLogic®, OpsLogic® Service Visibility Portal™, PLEXiS®, PowerSense™, QUARTET®, Regal®, ServAssure™, Service Visibility Portal™, TeleWire Supply®, TLX®, Touchstone®, EGT VIPr®, VoiceAssure™, VSM™, and WorkAssure™ are all trademarks of ARRIS Group, Inc. Other trademarks and trade names may be used in this document to refer to either the entities claiming the marks and the names of their products. ARRIS disclaims proprietary interest in the marks and names of others. © Copyright 2010 ARRIS Group, Inc. All rights reserved. Reproduction in any manner whatsoever without the express written permission of ARRIS Group, Inc. is strictly forbidden. For more information, contact ARRIS.